

LCC Modelling System

B 70-04 Early 20th century country Railway Station type 2

All drawings are not in scale.

LCC Modelling System is flexible and you can make easy modification. Please visit our website at www.lcut.co.uk to shop for additional LCC elements.

Footprint: 162mm x 362mm

Bundle contains:

- LCC 00-02 x2
- LCC 70-00 x3
- LCC 70-01 x3
- LCC 70-08 x1
- LCC 70-08A x1
- LCC 70-08F x1
- LCC 70-08FA x1
- LCC 70-09 x1
- LCC 70-13A x4
- LCC 70-21 x4
- LCC 70-34 x1
- LCC 70-35 x1
- LCC 70-38 x1
- LCC 72-00 x4
- LCC 72-01 x4
- LCC 72-02 x2
- LCC 72-03 x6
- LCC 72-07 x4
- LCC 72-16 x8
- LCC 72-25 x16
- LCC 72-27 x4
- LCC 74-99 x2
- LCC 74-100 x2
- LCC 74-101A x1
- LCC 74-101B x1

! We recommend PVA or any other paper/wood glue for the main fibre board parts and resin based glue for 3D printed parts.

Painting recommendation:

We recommend using acrylic paints. There is no need to undercoat the surface but it can be done if desired. The material used is porous and relatively forgiving, heavy coats are unlikely to flood the brickwork.

ELEVATIONS LAYOUT

PLATFORM ELEVATION



ROADSIDE ELEVATION

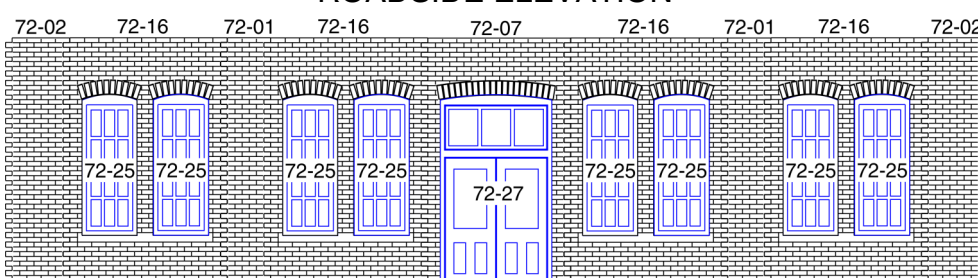

SIDE ELEVATIONS

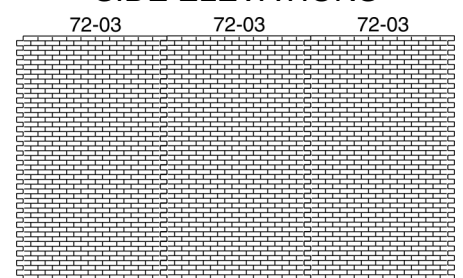

WINDOWS AND DOORS ASSEMBLY

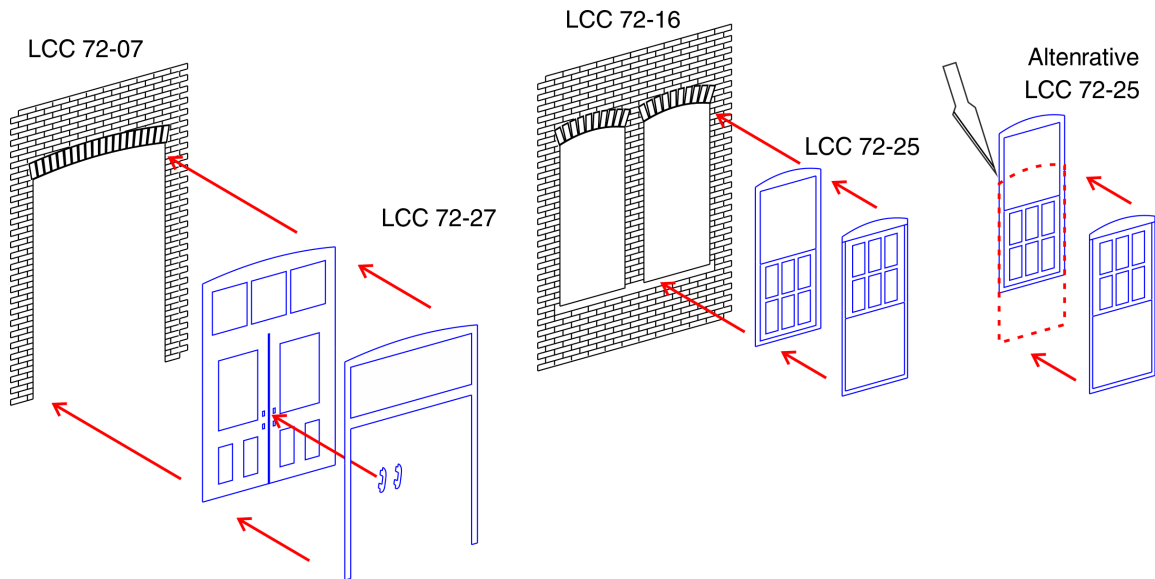

Alternatively it is possible to make the windows open by gluing the back element of LCC 72-25 higher and then trimming protruding window frame.

CONNECTING WALL ELEMENTS

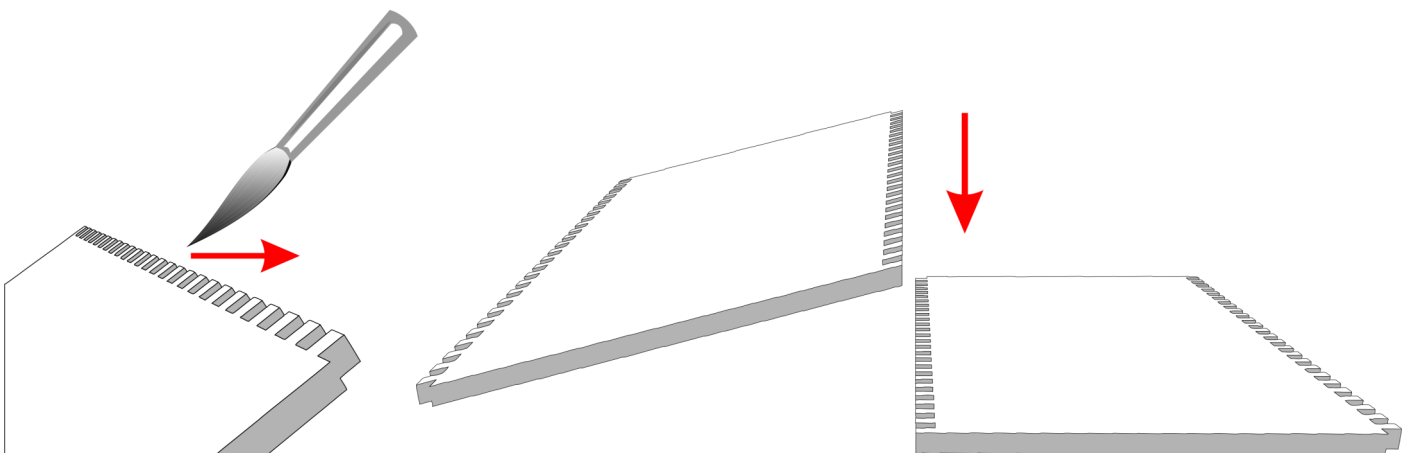

Recommended way of gluing parts together is to apply PVA glue to the interlocking bricks working from back of the part to the front. This ensures there will be no glue overflow on the front, visible side.

Then lay the part without glue on flat surface laying on its front (engraved side). Press the part with glue onto the part without glue. Gently push parts together from sides to close the gap.

INNER SUPPORTS

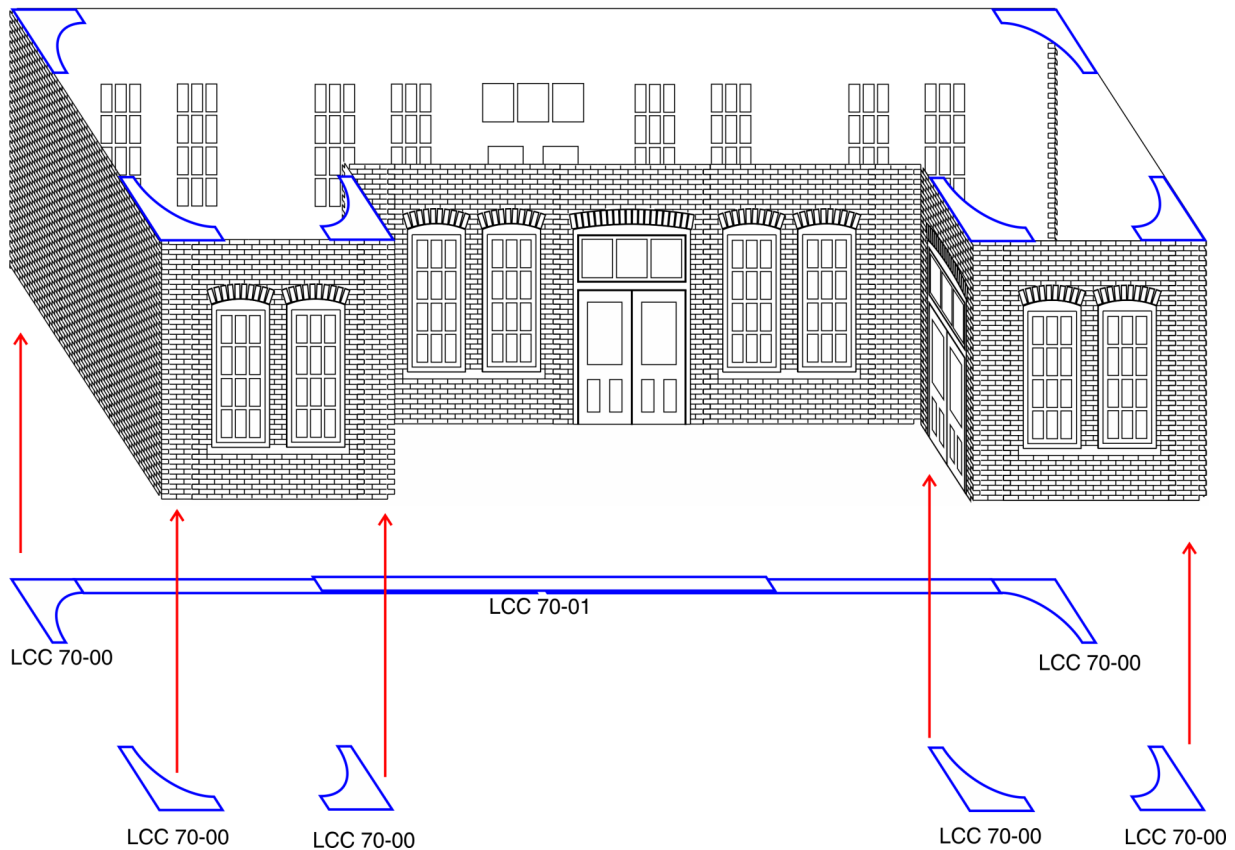

Glue provided corner supports (LCC 70-00) into inner corners as shown on the diagram. It is recommended to strengthen the roadside elevation with provided LCC 70-01. Glue 3 full length pieces from LCC 70-01 together with one overlapping on top. Then glue them to the bottom of the back of roadside elevation. Additional LCC 70-01 are provided if it is desired to strengthen any other elevations but it is not necessary. If the model is going to be glued to baseboard promptly it is possible to omit all of the above supports altogether.

CANOPY

To assemble canopy trim LCC 70-34 first to the width of the recess in platform elevation. Then trim LCC 70-34 into the depth of the recess minus 1.5mm for the valence. Glue the trimmed LCC 70-34 with the engraved side facing down. Then using LCC 70-35 build up a framework on the bottom side of the LCC 70-35 as shown on the diagram below. Trim LCC 70-38 to length and glue to the framework then finish with the provided strip found in the same spruce as LCC 70-38.

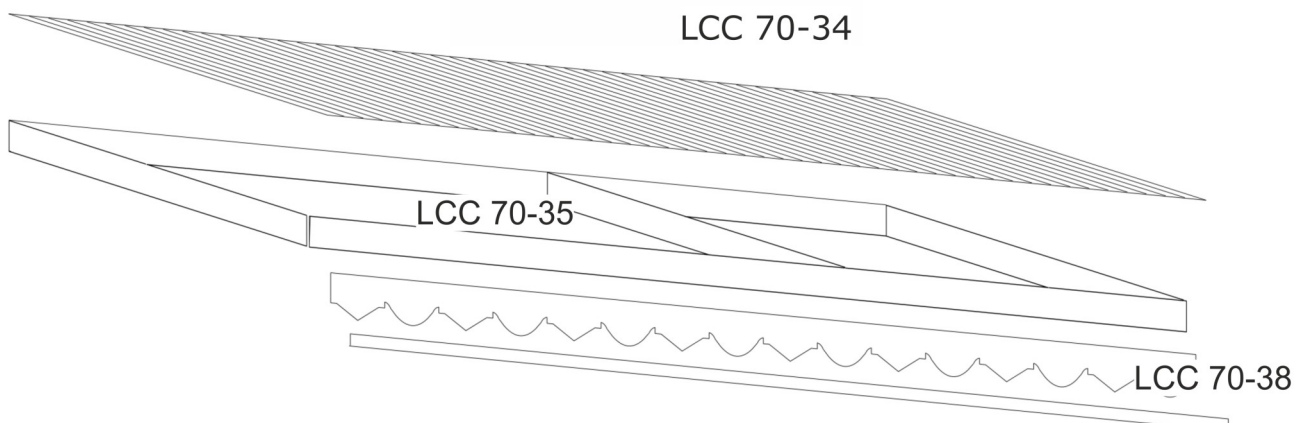

ROOF

Preparation:

Trim LCC 74-99 one row of bricks from the bottom. Glue LCC 74-100 to LCC 74-99 and trim the excess barge boards flush with the bottom of the gables. Trim LCC 70-21 from the bottom slightly shorter than LCC 74-99. Glue roof panels (LCC 70-13A, LCC 74-101A/B) together like the wall panels. Trim the roof panels to length of the building plus about 2.6mm for barge boards. Trim roof panels by 1 row of tiles if more close fitting roof is desired. Double up LCC 74-99 with LCC 70-21 to bring them to the same thickness as the wall panels.

Assembly:

Glue gables to the roof panels flush with the edges. It is recommended to glue middle LCC 70-21 after both halves of the roof were glued to the gables. Slide provided LCC 00-02 strips into the grooves in LCC 70-21 if desired. Gluing LCC 70-21 last is recommended method of obtaining minimal gap at the roof seam (ridge). If removable roof is not needed glue doubled up LCC 74-99 to the side elevations and then proceed to assemble rest of the roof. Glue assembled chimneys to the roof top. Fold the inner tabs of chimney flashing and glue around chimneys after they were glued to the roof. Fold LCC 70-09 in the middle and glue to the top of the roof. Finally glue the 3D printed chimney pots in place. Pots can be glued lower than usual but because of the taper more glue or filling will be required.

